

Programat[®] CS3

Short Instructions | Kurzanleitung | Mode d'emploi : l'essentiel
Istruzioni d'uso – versione ridotta | Guía rápida | Guia Rápido



CE

Programat® CS3

Short Instructions

Dear Customer

Thank you for having purchased the Programat® CS3. In order to render the setting-up and the initial use of the furnace as easy as possible, we have prepared these short instructions.



These short instructions replace by no means the detailed Operating Instructions. We therefore kindly ask you to thoroughly read the Operating Instructions and follow the notes contained therein.

Enjoy working with the Programat CS3.

1. Installation

Remove the furnace components from their packaging and place the unit on a suitable table. Please observe the instructions on the outer packaging. Make sure the voltage indicated on the rating plate complies with the local power supply. If this is not the case, the furnace must not be connected.

A Mounting the cooling tray

Remove both screws for the cooling tray (1).

B Place the cooling tray (2) on the frame plate (3).

Make sure that the cooling tray is correctly positioned on the frame plate.

C Secure the cooling tray with the two screws (1).

D Placing the firing plate

The firing plate (4) can now be placed on the firing plate holder (5).

E Mounting the furnace head

The furnace head is best mounted with the rear panel of the furnace pointing towards the user. Lift the furnace head with both hands as shown in the picture and place it on the furnace head mounting.

- F**  Mount the furnace head as shown in the picture until it audibly snaps into place. Make sure that the firing plate or the insulation is not damaged by mounting the furnace head.

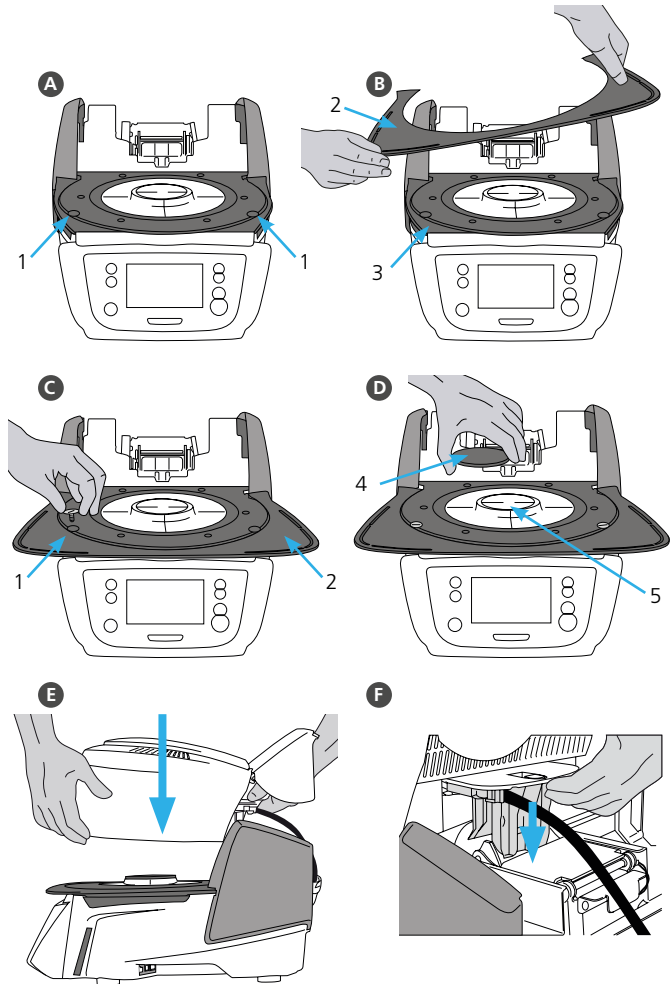

G Establishing the connections

Connect the cables of the furnace head with the furnace base.

Proceed as follows:

- Connect the vacuum hose (6).
- Insert the thermocouple plug (7). (Make sure that the polarity of the plug is correct.)
- Insert the heater plug (8).

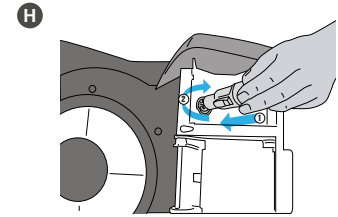
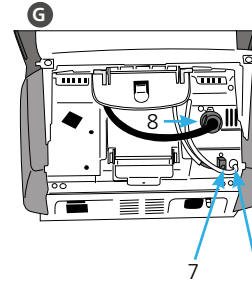

H Insert the heater plug into the intended connector. Secure the heater plug by rotating it 45°.

I Closing the covering hood

Once all cables are correctly connected to the furnace base, close the cover (9) to protect the connections until you feel it click into place.

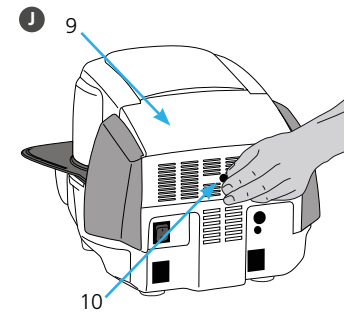
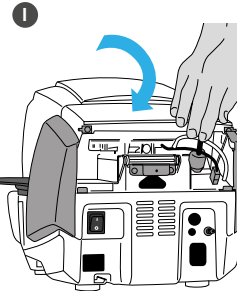

J Mounting the connection cover

The connection cover (10) can now be mounted and secured with the screws.



The furnace may only be used with the covering hood closed and the connection cover mounted!

K Establishing additional connections

Power connection

Make sure that the voltage indicated on the rating plate complies with the local power supply. Subsequently, connect the power cord (11) with the power socket of the Programat (12).

Connecting the vacuum pump

Connect the vacuum pump plug (13) with the vacuum pump socket (14). We recommend using only a vacuum pump from Ivoclar Vivadent, since these pumps are especially coordinated with the furnace. If other pumps are used, please observe and do not exceed the indicated maximum power consumption.

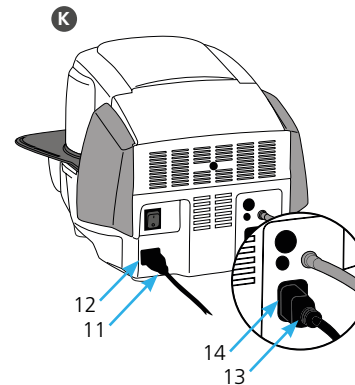

2. User interface

The Programat CS3 has a wide-screen colour display. The keypad and the touch screen allow user-friendly handling. By tapping slightly with your fingertips on the touch screen, the buttons are activated and the furnace performs the requested function.



Keypad:



Home

Returning to Home screen (main menu)



Power-saving key

This key activates the power-saving function.



Open furnace head



Close furnace head



START (Start LED)

Starts the selected program. The green LED indicates that a program is running. If the program is paused (1 x STOP), the Start LED flashes until renewed pressing of START results in the program being resumed.



STOP

A running program can be paused by pressing the STOP key and terminated by pressing the key twice. Movement of the furnace head can be stopped at any time by pressing STOP. Acoustic signals can be turned off by pressing the STOP key.



Program key

Pressing once: The currently selected program is displayed.

Pressing twice:

The program selection via number entry is accessed.



Digital Shade Assistant key

With this key, the Digital Shade Assistant (DSA) can be started and closed.

3. Operation

A Turning the furnace on

Connect the power cord with the wall socket.
Put the On/Off switch to position "I".

After the self-test, the display shows the Home screen or the last selected program.
To change to the Home screen, press the HOME key. All functions of the Programat can be selected from this screen.

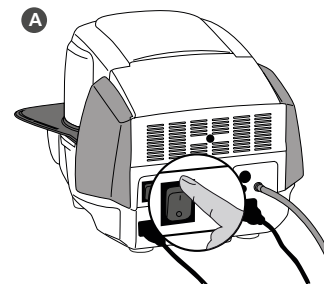

B Selecting the program

Select the required program.

Loading the furnace

Open the furnace head by pressing the OPEN FURNACE HEAD key and place the object to be fired with the firing tray in the furnace.

C Starting the program

Press the START key to start the program. The LED lights up green.
The program progress is shown in the display.



At the end of the program, the furnace head opens automatically. As soon as the OSD lights up green, the furnace is available for the next program start.

4. Editing the firing parameters

Parameters are set or edited in two steps.

Example: Setting the holding temperature

- A** In the program screen, press the [Parameter] button.
- B** Press the [T] button.
- C** Enter the desired holding temperature and confirm by pressing the green button.

The holding temperature has been changed successfully. All parameters shown in the firing curve can be changed / edited the same way.

Changing program options

By pressing the [Options] button, the menu for additional program options opens.

Example: Open the write-protection program

- A** In the program screen, press the [Parameter] button.
- B** Press the [Options] button.
- C** Edit the desired option and return to the program view by pressing the [Close] button.

By pressing the **[Arrow]** buttons, you can change between the individual option pages.



Ivoclar Vivadent programs are partially blocked and cannot be edited.
Please refer to the Operating Instructions for more detailed information.

Programat[®] CS3

Kurzanleitung

Sehr geehrter Kunde

Es freut uns, dass Sie sich für den Kauf des Programat[®] CS3 entschieden haben. Um Ihnen die Inbetriebnahme und die erste Anwendung des Gerätes so einfach wie möglich zu gestalten, haben wir diese Kurzanleitung verfasst.



**Diese Kurzanleitung ersetzt keinesfalls die umfassende Bedienungsanleitung.
Wir bitten Sie daher, auch die Bedienungsanleitung genau durchzulesen und die Hinweise zu beachten.**

Wir wünschen Ihnen viel Freude und Erfolg mit dem Gerät.

1. Installation

Gerätekomponenten aus der Verpackung nehmen und das Gerät auf einen geeigneten Tisch stellen. Bitte beachten Sie die Anleitung auf der Aussverpackung. Prüfen Sie, ob die angegebene Spannung des Typenschildes mit der vorhandenen Netzspannung übereinstimmt. Ist dies nicht der Fall, darf das Gerät nicht angeschlossen werden!

A Montage der Brenngut-Ablageplatte

Entfernen Sie die zwei Befestigungsschrauben für die Brenngut-Ablageplatte (1).

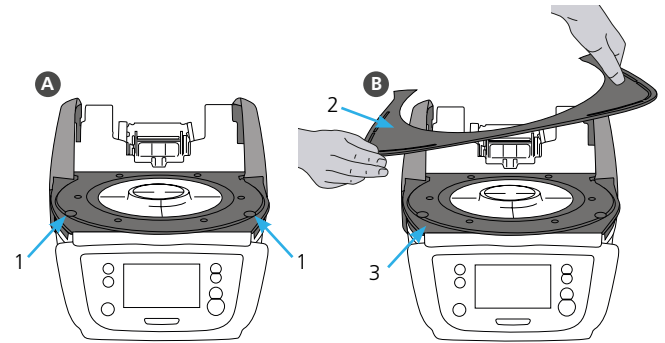

B Legen Sie nun die Brenngut-Ablageplatte (2) auf die Rahmenplatte (3).

Achten Sie dabei, dass die Brenngut-Ablageplatte korrekt auf der Rahmenplatte aufliegt.

C Sichern Sie nun die Brenngut-Ablageplatte mit den zwei Befestigungsschrauben (1).

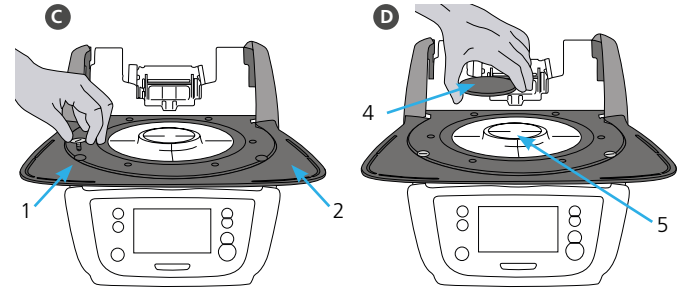



D Brenntisch auflegen

Der Brenntisch (4) kann nun auf die Brenntischaufnahme (5) aufgelegt werden.

E Ofenkopf montieren

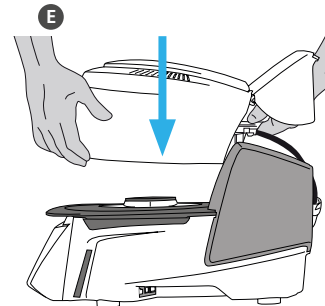
Der Ofenkopf kann am einfachsten montiert werden, wenn die Ofen-Rückseite zum Anwender zeigt. Heben Sie den Ofenkopf mit beiden Händen auf dem Bild ersichtlich und setzen Sie ihn auf die Ofenkopfhalterung.



- F  Die Ofenkopfhalterung wie auf dem Bild ersichtlich aufsetzen bis der Ofenkopf spürbar einrastet. Achten Sie darauf, dass der Brenntisch bzw. die Isolation durch die Ofenkopfmontage nicht beschädigt wird.

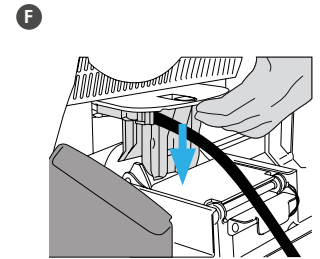

G Anschlüsse herstellen

Verbinden Sie nun die Kabel des Ofenkopfes mit dem Ofen-Unterteil. Gehen Sie dabei wie folgt vor:

- Vakuumschlauch anschliessen (6)
- Stecker Thermoelement (7) einstecken (auf richtige Polung achten)
- Stecker Heizung einstecken (8)

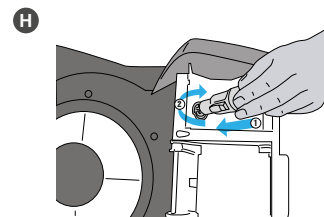
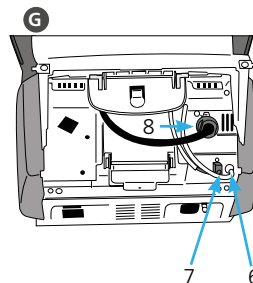

- H** Stecken Sie den Heizungsstecker in den vorgesehenen Anschluss. Fixieren Sie den Heizungsstecker durch eine 45° Drehung.

I Abdeckhaube anklappen

Wenn alle Kabel korrekt mit dem Ofen-Unterteil verbunden sind, klappen Sie die Abdeckhaube (9) über die Anschlüsse bis jene einrastet.

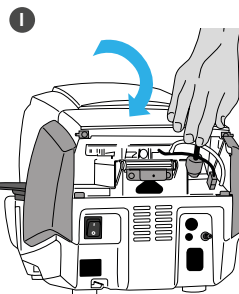
**J Anschlussabdeckung montieren**

Nun kann die Anschlussabdeckung (10) aufgesetzt und mit der Befestigungsschraube fixiert und gesichert werden.

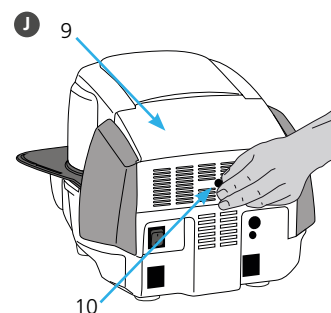

Das Gerät darf nur mit angeklappter Abdeckhaube und montierter Anschlussabdeckung in Betrieb genommen werden!

K Weitere Anschlüsse herstellen**Netzanschluss herstellen**

Bitte überprüfen Sie vor dem Anschliessen, ob die Netzspannung mit Ihrer örtlichen Netzspannung übereinstimmt. Anschliessend können Sie das Netzkabel (11) mit der Gerätesteckdose (12) verbinden.

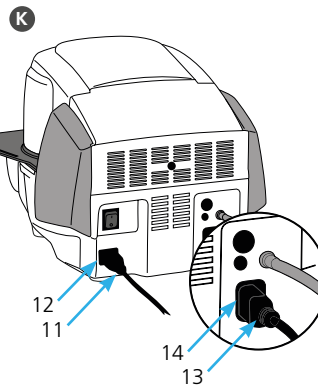
**Vakuumpumpe anschliessen**

Stecken Sie den Vakuumpumpen-Netzstecker (13) in die Vakuumpumpe-Gerätesteckdose (14). Wir empfehlen Ihnen eine Vakuumpumpe von Ivoclar Vivadent zu verwenden, da diese Pumpen speziell auf den Brennofen abgestimmt sind. Falls eine andere Vakuumpumpe angeschlossen wird, beachten Sie dabei bitte die maximal zulässige Leistungsaufnahme auf dem Typenschild.

2. Bedienelemente

Der Programat CS3 verfügt über ein Breitbild-Farbdisplay. Die intuitive Bedienung erfolgt über die Folientastatur und den Touch-Screen. Durch leichtes Antippen der Anzeige mit der Fingerkuppe können Touch-Buttons betätigt werden und das Gerät führt die gewünschte Funktion aus.



Folientasten:



Home

Wechsel zum „Home-Screen“ (Hauptmenü)



Stromspar-Taste

Mit dieser Taste wird die Stromspar-Funktion aktiviert.



Ofenkopf öffnen



Ofenkopf schliessen



START (Start-LED)

Startet das gewählte Programm. Ein aktives Programm wird durch die grün leuchtende LED signalisiert. Wird das Programm pausiert (1 x STOP), blinkt die Start-LED bis zur Fortsetzung durch erneutes START.



STOP

Ein aktives Programm kann durch Drücken der STOP-Taste pausiert und durch zweimaliges Drücken beendet werden. Eine Kopfbewegung kann mit der STOP-Taste jederzeit angehalten werden. Signaltöne können mit der STOP-Taste quitiert werden.



Programm-Taste

Einmaliges Drücken: Anzeige des aktuell gewählten Programms.

Zweimaliges Drücken:

Wechsel in die Programmauswahl via Nummern-Eingabe



Digital Shade Assistant-Taste

Mit dieser Taste kann der Digital Shade Assistant (DSA) gestartet und beendet werden.

3. Bedienung

A Einschalten

Verbinden Sie das Netzkabel mit dem Leitungsnetz und schalten Sie den Ein-/Aus-Schalter auf der Geräterückseite auf die Position "I".

Nach dem Selbsttest des Gerätes erscheint die Programmanzeige bzw. das zuletzt gewählte Programm. Mit der HOME-Taste kann in den Home-Screen gewechselt werden. Über diesen können sämtliche Funktionen des Programats angewählt werden.

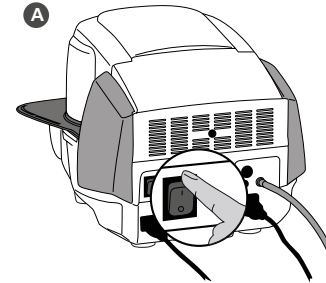

B Programm wählen

Wählen Sie mit den [Pfeil]-Buttons das gewünschte Programm.

Bestücken des Ofens

Öffnen Sie den Ofenkopf mit der Taste OFENKOPF ÖFFNEN und stellen Sie das Brennobjekt mit dem Brenngutträger in den Ofen.

C Programm Starten

Drücken Sie die START-Taste, das Programm wird gestartet und die LED-Anzeige leuchtet grün. Auf dem Display wird der Programmfortschritt angezeigt.

Am Ende des Programms öffnet der Ofenkopf automatisch. Sobald die OSD-Anzeige grün leuchtet, steht der Ofen für den nächsten Programmstart zur Verfügung.



4. Brennparameter editieren

Die Eingabe bzw. das Editieren eines Parameters erfolgt in zwei Schritten
z. B. Einstellen der Haltetemperatur:

- A In der Programmanzeige auf den [Parameter]-Button drücken.
- B Auf den Button [T] drücken
- C Gewünschte Haltetemperatur eingeben und mit grünem Button bestätigen

Die Haltetemperatur wurde somit erfolgreich geändert. Alle anderen in der Brennkurve dargestellten Parameter können auf selbe Weise verändert/editiert werden.

Programm-Optionen ändern

Durch Drücken des Buttons **[Optionen]** öffnet sich das Menü für erweiterte Programmoptionen.

z.B. Programmschreibschutz öffnen

- A In der Programmanzeige auf den [Parameter]-Button drücken.
- B Auf den Button [Optionen] drücken
- C Gewünschte Option editieren und mit dem [Schliessen]-Button in die Programmanzeige wechseln.

Mit den **[Pfeil]**-Buttons kann zwischen den einzelnen Optionenseiten gewechselt werden.



Ivoclar Vivadent Programme sind teilweise gesperrt und können nicht verändert werden.
Ausführliche Informationen zur weiteren Anwendung entnehmen Sie bitte der Bedienungsanleitung.

Programat[®] CS3

Mode d'emploi : l'essentiel

Cher client,

Nous vous remercions d'avoir fait l'acquisition du Programat CS3. Les instructions ci-après vous permettront de simplifier au maximum la configuration et la première utilisation de votre four.



Ces brèves instructions ne se substituent en aucun cas au Mode d'emploi détaillé. Par conséquent, nous vous demandons de bien vouloir lire attentivement le Mode d'emploi et d'en suivre les consignes.

Travaillez en toute simplicité avec le Programat CS3.

1. Installation

Déballer les composants du four et placer l'unité sur une table adaptée. Respecter les consignes indiquées sur l'emballage extérieur. Veiller à s'assurer que la tension indiquée sur la plaque d'identification est conforme à l'alimentation locale. Dans le cas contraire, ne pas brancher le four.

A Montage de la tablette de service

Retirer les deux vis de la tablette de service (1).

B Poser la tablette de service (2) sur la plaque supérieure (3).

Veiller à ce que la tablette de service soit correctement positionnée sur la plaque supérieure.

C Fixer la tablette de service (1) à l'aide des deux vis.

D Positionnement de la table de cuisson

La table de cuisson (4) peut alors être positionnée sur son support (5).

E Montage de la tête du four

Le plus simple est de monter la tête du four lorsque le panneau arrière du four se trouve face à l'utilisateur. Soulever des deux mains la tête du four, tel qu'indiqué sur l'image, et la positionner sur le support.

- F  Monter la tête du four tel qu'illustré sur l'image jusqu'à ce qu'elle se trouve en place et qu'un clic se fasse entendre. Veiller à ce que la table de cuisson et l'isolation ne soient pas endommagées pendant le montage de la tête du four.

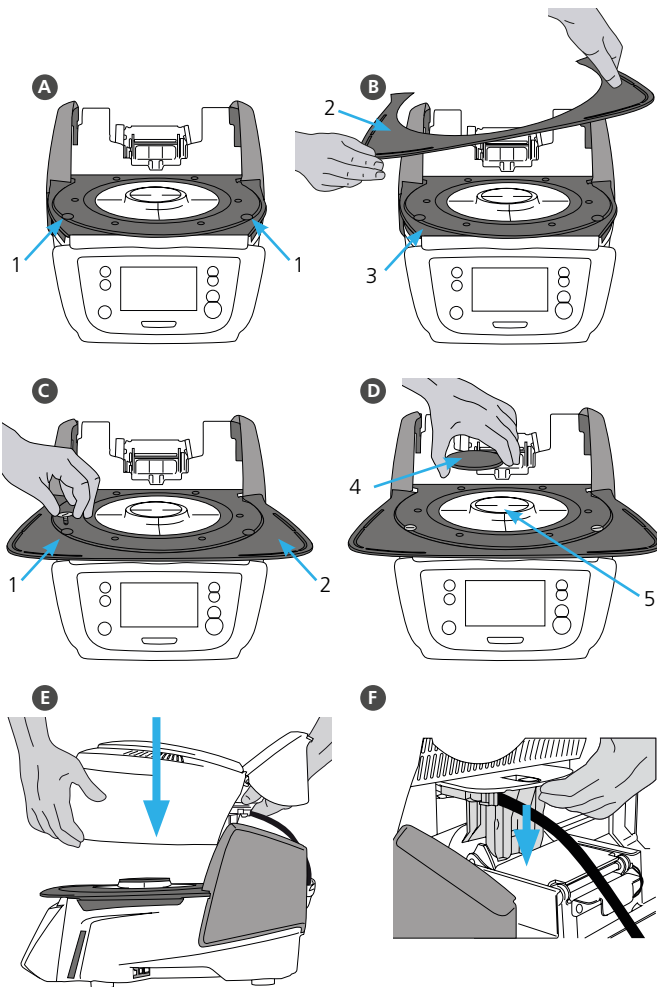

G Établir les branchements

Relier les câbles de la tête du four à la partie inférieure.

Procéder comme suit :

- Raccorder le tuyau de vide (6).
- Insérer la fiche du thermocouple (7) (veiller à bien respecter la polarité).
- Insérer la fiche de chauffe (8).

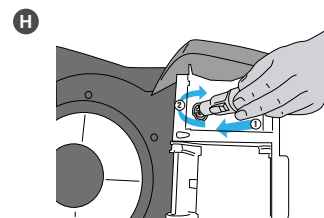
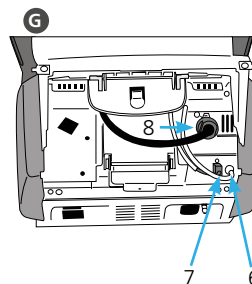

- H Insérer la fiche de chauffe dans le connecteur spécifié. Sécuriser la fiche de chauffe grâce à une rotation de 45°.

I Fermeture du capot de protection

Une fois tous les câbles correctement reliés à la base du four, abaisser le capot (9) de protection des branchements jusqu'à ce qu'il soit en place et qu'un clic se fasse entendre.

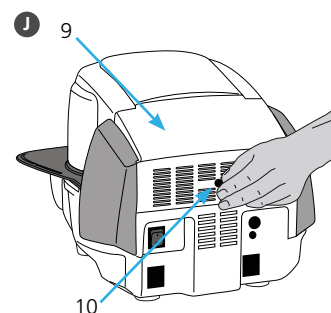
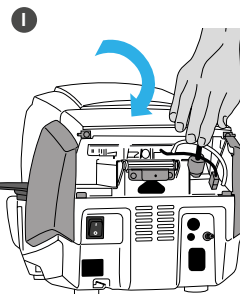

J Montage du couvercle de protection des branchements

Le couvercle de protection des branchements (10) peut alors être monté et fixé à l'aide des vis.



Le four ne peut être utilisé qu'avec le capot de protection fermé et le couvercle de protection des branchements monté !

K Établir d'autres branchements

Alimentation

Veiller à ce que la tension indiquée sur la plaque d'identification soit conforme à l'alimentation locale. Relier ensuite le cordon d'alimentation (11) à la prise correspondante du Programat (12).

Branchement de la pompe à vide

Relier la fiche de la pompe à vide (13) à la prise de la pompe (14). Nous recommandons l'utilisation exclusive de la pompe à vide d'Ivoclar Vivadent, étant donné que ces pompes sont spécialement adaptées à ce four. En cas d'utilisation d'une autre pompe, respecter impérativement la consommation maximale indiquée.

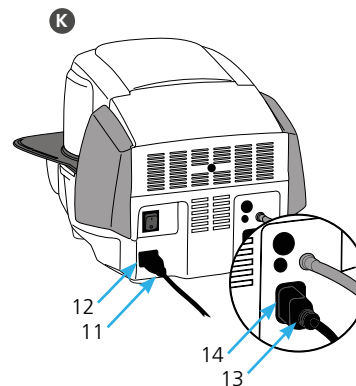

2. Interface utilisateur

Le Programat CS3 est doté d'un grand écran couleur. Le clavier et l'écran tactile permettent une utilisation conviviale. Appuyer légèrement sur l'écran tactile du bout des doigts permet d'activer les boutons. Le four exécute alors la fonction demandée.



Clavier :



Accueil

Retour à l'écran d'accueil (menu principal)



Bouton d'économie d'énergie

Ce bouton permet d'activer la fonction d'économie d'énergie.



Ouverture de la tête du four



Fermeture de la tête du four



START (LED de démarrage)

Permet de lancer le programme sélectionné. La LED verte indique qu'un programme est en cours. Si le programme est interrompu (1 x STOP), la LED de démarrage clignote jusqu'à ce que le bouton START soit à nouveau activé pour reprendre le programme.



STOP

Un programme en cours peut être interrompu en appuyant sur le bouton STOP et annulé en appuyant deux fois. Le bouton STOP permet d'immobiliser la tête du four à n'importe quel moment. Les signaux sonores peuvent être désactivés au moyen du bouton STOP.



Bouton Programme

1 activation : Le programme sélectionné s'affiche.

2 activations :

La sélection de programme par saisie de numéro est activée.



Touche Digital Shade Assistant

Grâce à cette touche, l'assistant Digital Shade Assistant (DSA) peut être démarré ou fermé.

3. Fonctionnement

A Mise sous tension du four

Relier le cordon d'alimentation à la prise murale.
Placer l'interrupteur sur la position "I".

Après l'auto-test, l'écran affiche la page d'accueil ou le dernier programme sélectionné.
Pour passer à la page d'accueil, cliquer sur la touche HOME. Toutes les fonctions du Programat peuvent être sélectionnées dans cet écran.

B Sélection d'un programme

Sélectionner le programme désiré.

Chargement du four

Ouvrir la tête du four en appuyant sur le bouton OPEN FURNACE HEAD et placer l'objet à cuire et la table de cuisson dans le four.

C Démarrage d'un programme

Appuyer sur le bouton START pour démarrer le programme. La LED passe au vert. La courbe de cuisson indique la progression du programme.

À la fin du programme, la tête du four s'ouvre automatiquement. Dès que l'affichage passe au vert, le four est disponible et le programme suivant peut être lancé.

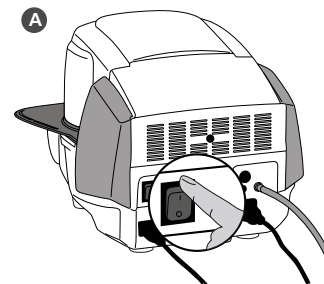

4. Modification des paramètres de cuisson

Les paramètres peuvent être définis ou modifiés en deux étapes.

Exemple : Réglage de la température de maintien

A Dans l'écran du programme, appuyer sur le bouton [Paramètres].

B Appuyer sur le bouton [T].

C Saisir la température de maintien souhaitée et confirmer en appuyant sur le bouton vert.

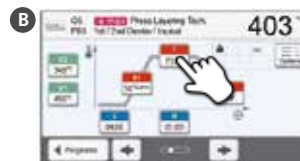

La température de maintien a été modifiée avec succès. Tous les paramètres indiqués sur la courbe de cuisson peuvent être modifiés/édités selon la même procédure.

Modification des options d'un programme

Appuyer sur le bouton [Options] permet d'ouvrir le menu des options de programme complémentaires.
par ex. : ouverture de la protection d'écriture du programme

A Dans l'écran du programme, appuyer sur le bouton [Paramètres].

B Appuyer sur le bouton [Options].

C Modifier l'option souhaitée et retourner à l'aperçu du programme en appuyant sur le bouton [Fermer].



Appuyer sur les boutons [Flèche] permet de naviguer dans les pages d'options.



Les programmes Ivoclar Vivadent sont partiellement bloqués et ne peuvent pas être édités.
Veuillez consulter le mode d'emploi pour des informations plus détaillées.

Programat[®] CS3

Istruzioni d'uso – versione ridotta

Egregio cliente,

siamo lieti che abbia acquistato Programat CS3. La presente istruzione d'uso in versione ridotta, è stata realizzata per facilitare la messa in funzione ed il primo utilizzo dell'apparecchio.



**La versione ridotta delle istruzioni d'uso NON sostituisce le istruzioni d'uso nella versione completa.
La preghiamo pertanto di leggere attentamente anche le istruzioni d'uso e di rispettare le avvertenze.**

Le auguriamo buon lavoro e tanto successo con l'apparecchio.

1. Installazione

Disimballare l'apparecchio, attenendosi alle istruzioni riportate sul confezionamento esterno e posizionarlo su un idoneo ripiano. Osservare le istruzioni sul confezionamento esterno. Controllare che il voltaggio riportato sulla targhetta corrisponda alla tensione di rete locale. Se non corrisponde, l'apparecchio non deve essere allacciato!

A Montaggio della piastra di appoggio

Rimuovere le due viti di fissaggio per la piastra di appoggio (1).

B Appoggiare la piastra di appoggio (2) sul telaio (3), prestando attenzione che sia appoggiata correttamente.

C Fissare quindi la piastra di appoggio con le due viti di fissaggio (1).

D Inserimento del piano di cottura

Inserire quindi il piano di cottura (4) nell'apposito alloggiamento (5).

E Montaggio della cappa del forno

Il modo più semplice per montare la cappa è di posizionare la base del forno con il retro dell'apparecchio rivolto verso l'operatore. Sollevare la cappa con entrambe le mani come da immagine e posizionare la cappa sul proprio supporto.

F  Inserire la cappa come illustrato nell'immagine fino a percepire uno scatto. Durante il montaggio, prestare attenzione a non danneggiare il piano di cottura e l'isolamento.

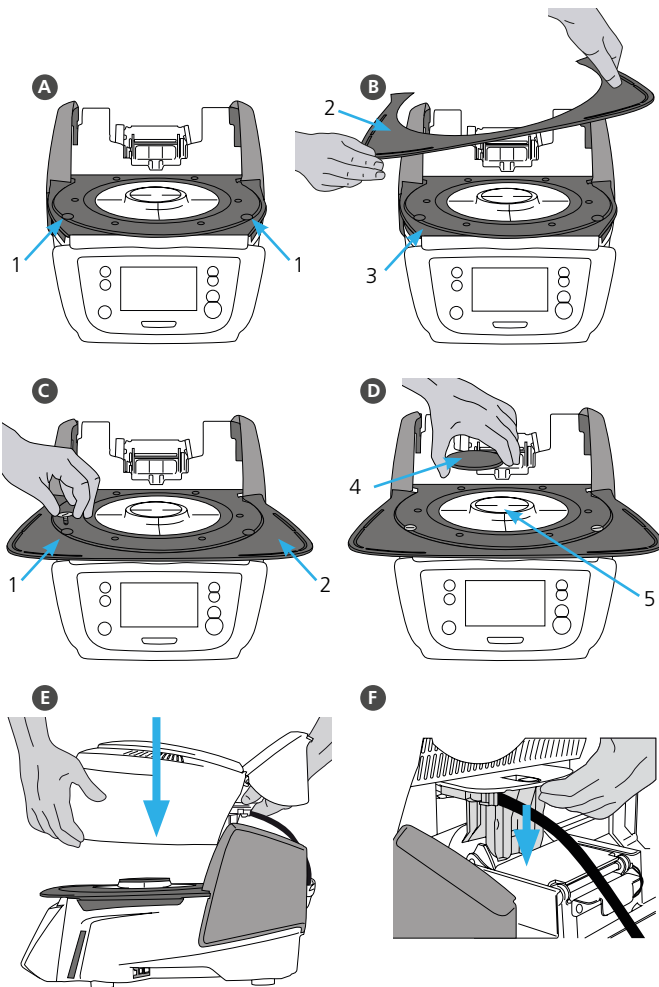

G Allacciamenti

Collegare i cavi della cappa con la base del forno.

Procedere come segue:

- collegare il tubo per il vuoto (6)
- inserire la spina del termoelemento (7) (prestare attenzione alla corretta polarizzazione)
- inserire la spina della resistenza (8)

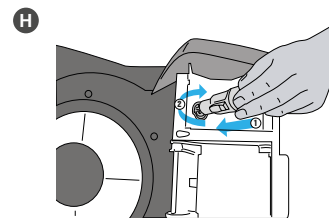
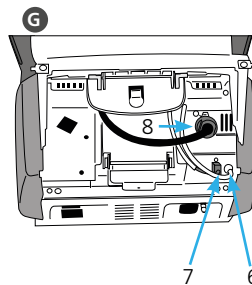

H Inserire la spina della resistenza nell'apposito allacciamento. Fissare la spina della resistenza con un movimento di 45°.

I Apertura della cappa

Non appena i cavi sono correttamente collegati con la base del forno, aprire la cappa (9) sugli allacciamenti finché si avverte uno scatto.

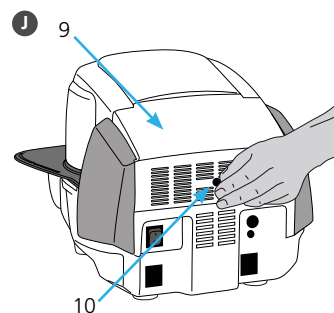
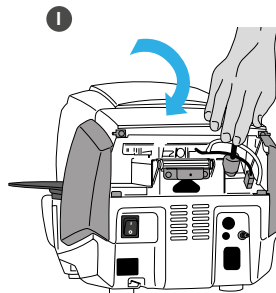

J Montaggio della copertura degli allacciamenti

Ora è possibile applicare la copertura (10) e fissarla con la vite di fissaggio.



L'apparecchio può essere messo in funzione soltanto con cappa chiusa e copertura montata!

K Allacciamento elettrico

Prima dell'allacciamento, si prega di controllare che la tensione di rete corrisponda a quella riportata sulla targhetta. Quindi collegare il cavo (11) con la presa dell'apparecchio (12).

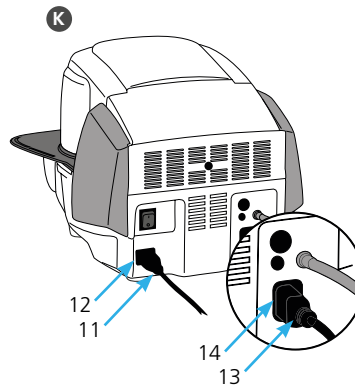

Allacciamento pompa del vuoto

Inserire la spina della pompa del vuoto (13) nell'apposita presa dell'apparecchio (14). Si consiglia l'utilizzo di una pompa per il vuoto della Ivoclar Vivadent AG, poiché queste pompe sono specificatamente calibrate con il forno. In caso di utilizzo di un altro tipo di pompa, è assolutamente necessario attenersi all'assorbimento di potenza massimo ammesso riportato sulla targhetta.

2. Comandi

Il Programat CS3 dispone di un ampio display a colori. L'utilizzo intuitivo avviene attraverso tastiera a sfioramento e Touch-Screen. Premendo leggermente si attivano i tasti e l'apparecchio esegue la funzione desiderata.

Tasti a sfioramento:



Home

Per passare alla videata „Home-Screen“ (menù principale).



Tasto risparmio energetico

Con questo tasto si attiva la funzione di risparmio energetico.



Apertura della cappa



Chiusura della cappa



START (Start-LED)

Avvia il programma desiderato. Un programma attivo viene segnalato dal LED verde illuminato. Se il programma è in pausa (1 x STOP) il LED del tasto Start lampeggia fino a ripresa del programma con il tasto START.



STOP

Un programma attivo può essere messo in pausa premendo il tasto STOP una volta e terminato premendo il tasto STOP per due volte. Un movimento della cappa può essere interrotto in qualsiasi momento premendo il tasto STOP. Anche il segnale acustico può essere confermato con il tasto STOP.



Tasto Programma

Premuto una volta: visualizzazione del programma scelto.

Premuto due volte:

passaggio alla scelta del programma tramite inserimento numerico



Tasto Digital Shade Assistant

Con questo tasto è possibile avviare e fermare il Digital Shade Assistant (DSA).

3. Utilizzo

A Accensione

Collegare il cavo di allacciamento con la rete e portare l'interruttore di accensione/spengimento sul retro dell'apparecchio in posizione "I".

Dopo l'autodiagnosi appare la videata Homescreen o l'ultimo programma selezionato. Per passare alla videata Homescreen, premere il tasto HOME. Da questa videata si possono scegliere tutte le funzioni del Programat.

B Selezione del programma

Scegliere il programma desiderato.

Inserimento nel forno

Aprire la cappa del forno con il tasto APERTURA CAPPa e posizionare il restauro con il portaoggetti nel forno.

C Avvio programma

Premendo il tasto START, il programma viene avviato ed il LED verde si illumina. Sull'immagine della curva di cottura si può osservare il decorso.

Al termine del programma la cappa si apre automaticamente. Non appena la visualizzazione OSD si illumina in colore verde, il forno è disponibile per l'avvio del prossimo programma.

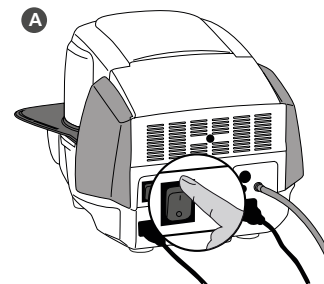

4. Inserimento parametri di cottura

L'inserimento dei parametri avviene in due fasi
p.es. inserimento della temperatura di tenuta

A Nella visualizzazione programma, premere il tasto [Parametri]

B Premere il tasto [T]

C Inserire la temperatura di tenuta desiderata e confermare con il tasto verde

In tal modo la temperatura di tenuta è stata modificata con successo. Tutti gli altri valori raffigurati nella curva di cottura possono essere modificati/inseriti allo stesso modo.

Modifica opzioni del programma

Premendo il tasto [Opzioni] si apre il menù per le opzioni di programma ampliate.

p. es.: apertura protezione da scrittura

A Nella visualizzazione programma, premere il tasto [Parametri].

B Premere il tasto [Opzioni]

C Modificare l'opzione desiderata e tornare nella visualizzazione programma con il tasto [Chiusura].

Con i tasti [freccia]- si può navigare fra le singole pagine delle opzioni.



I programmi Ivoclar Vivadent sono parzialmente bloccati e non possono essere modificati.
Per informazioni più dettagliate consultare le istruzioni d'uso.

Programat[®] CS3

Guía rápida

Estimado cliente

Gracias por haber adquirido el Programat CS3. Con el objetivo de que los ajustes y el uso inicial del horno sea lo más fácil posible, hemos preparado esta guía rápida.



Esta guía rápida no sustituye al manual de instrucciones detalladas. Por lo tanto, le rogamos que lea detenidamente las instrucciones de uso y siga con las indicaciones que figuran en él.

Disfrute de su trabajo con Programat CS3.

1. Instalación

Retirar todos los componentes del horno de la caja y colocar la unidad en un sitio adecuado. Por favor tener en cuenta las instrucciones del exterior del embalaje. Asegúrese de que el voltaje indicado en la placa de características cumple con la fuente de alimentación local. Si no lo cumple no conectar el horno.

A Montaje de la bandeja de enfriamiento

Retirar ambos tornillos de la bandeja de enfriamiento (1)

B Colocar la bandeja de enfriamiento (2) en la placa del bastidor(3)

Asegúrese que la bandeja de enfriamiento está correctamente posicionada en la placa del bastidor

C Colocar la bandeja de enfriamiento con los dos tornillos (1)

D Colocar la plataforma de cocción

La plataforma de cocción (4) ahora puede ser colocada en el hueco de la plataforma (5)

E Montar la cabeza del horno

La cabeza del horno se monta mejor con el panel trasero del horno mirando hacia el usuario. Levantar el cabezal del horno con ambas manos, como se muestra en la imagen y colocarla en el montaje de cabezal del horno.

- F  Colocar la cabeza del horno como muestra la imagen hasta que se oiga un click. Asegurarse de que ni la plataforma de cocción ni el aislamiento esté dañado durante el montaje del cabezal del horno.

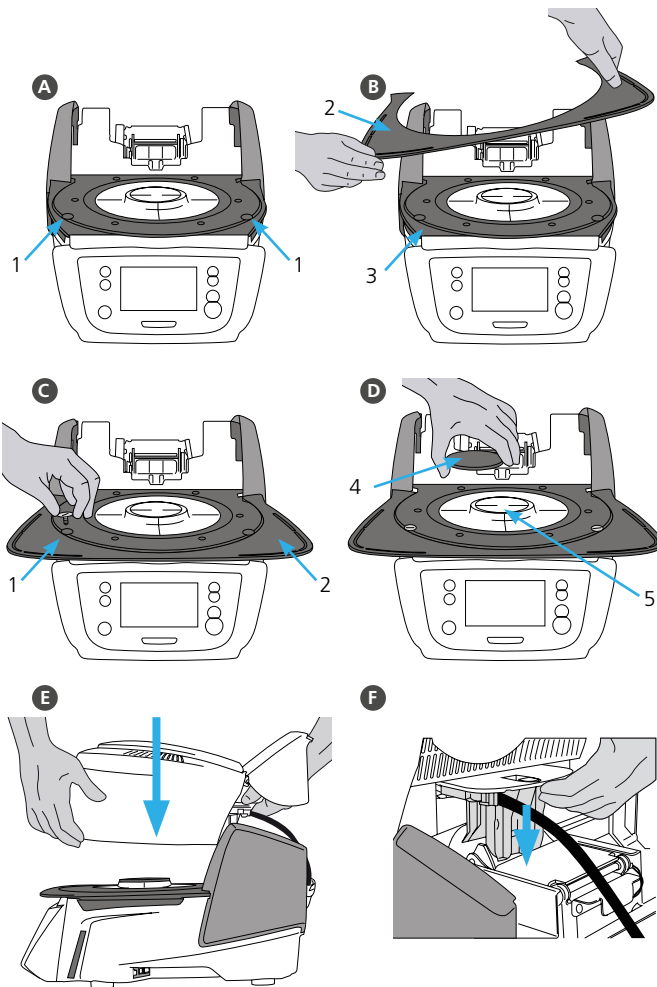

G Establecer las conexiones

Conectar los cables de la cabeza del horno con la base.

Proceder de la siguiente manera:

- Conectar la bomba de vacío (6)
- Insertar el enchufe termopar (7)
- (asegúrese que la polaridad del enchufe sea la correcta)
- Insertar el enchufe de la resistencia (8)

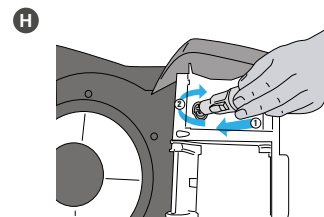
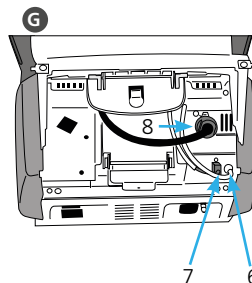

H Insertar el enchufe de la resistencia en el conector específico.

Asegurar rotándolo 45°.

I Cerrar la tapa protectora

Cuando todos los cables estén correctamente conectados a la base del horno, cerrar la tapa (9) para proteger la conexión hasta que se oiga click.

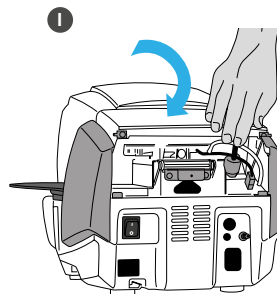

J Montar la tapa de conexión

Ahora se pueden montar la tapa de conexión (10) asegurándola con tornillos.

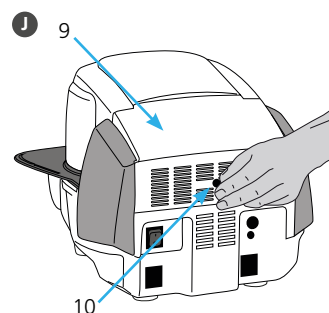

El horno debe usarse únicamente con la tapa de protección colocada, y la tapa de conexión montada!

K Establecer conexiones adicionales

Conexión a la red

Asegúrese de que el voltaje indicado en la placa cumple con la fuente de alimentación local. Posteriormente, conectar el cable (11) con el Programat (12).

Conectar la bomba de vacío

Conectar el cable a la bomba de vacío (13)(14). Se recomienda usar sólo la bomba de vacío de Ivoclarc Vivadent, debido a que estas bombas están especialmente coordinadas con el horno. Si se usan otras bombas de vacío, por favor revise que no exceda el máximo indicado de consumo de energía.

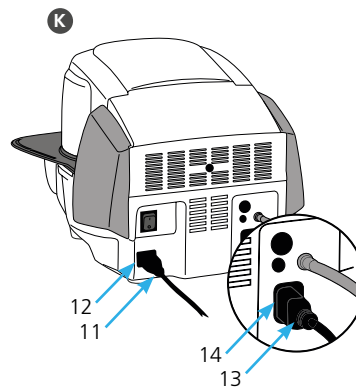

2. Usar la interface

El horno Programat CS3 tiene una amplia pantalla a todo color. El teclado y la pantalla táctil permiten un manejo sencillo. Con un simple toque con los dedos en la pantalla táctil, los botones se activarán y el horno realizará la función requerida.

Teclado



Home

Regresa a la pantalla de (home) inicio (menú principal)



Botón Power-Saving

Este botón activa la función de ahorro de energía



Apertura del horno



Cerrar la tapa del horno



START Inicio

Empieza con el programa seleccionado. La luz azul indica que el programa está en marcha. Si el programa se pausa (1x STOP), la luz de Start parpadeará hasta que se vuelva a presionar por lo que se reanuda el programa.



STOP

El programa en funcionamiento puede pausarse presionando el botón STOP y finalizarse presionando el botón dos veces. Los movimientos de la tapa del horno se pueden parar en cualquier momento presionando el STOP. Las señales acústicas pueden eliminarse presionando el botón STOP.



Botones de Programación

Presionando una vez: Aparecerá en la pantalla el programa que está en uso.

Presionando dos veces:

Se accede a la selección del programa a través del número.



Tecla Asistente Digital del Color (Digital Shade Assistant – DSA)

Con esta tecla, el Asistente Digital del Color (DSA) se inicia o finaliza.

3. Manejo

A Poniendo el horno en marcha

Conectar el cable de alimentación.

Presionar el botón de encendido y apagado en la posición "I"

Tras la autocomprobación, aparecen la pantalla de inicio o el último programa seleccionado. Para ir a la pantalla de inicio, pulse la tecla HOME. Desde esta pantalla pueden seleccionarse todas las funciones del Programat.

B Selección de programas

Seleccionar el programa requerido

Carga del horno

Abrir el horno presionando el botón APERTURA DEL HORNO y colocar el objeto a cocer en la bandeja de cocción del horno.

C Empezar el programa

Presionar el botón START para empezar. La luz verde se encenderá.

La pantalla mostrará el progreso a través de la curva de cocción.

Al finalizar el programa, el horno se abrirá automáticamente.

Tan pronto como las luces de OSD estén en verde, el horno estará disponible para empezar un nuevo programa.

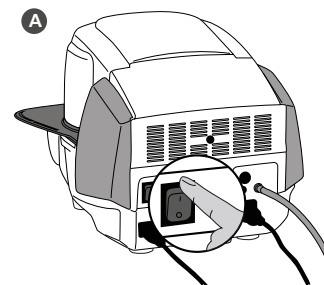

4. Editando los parámetros de cocción

Los parámetros se ajustan o editan en dos pasos.

Ejemplo: Ajustando la temperatura de mantenimiento

- A** En la pantalla del programa, pulse el botón [Parámetro].
- B** Presionar el botón [T].
- C** Introducir la temperatura de mantenimiento y confirmar presionando el botón verde.



La temperatura de mantenimiento habrá sido cambiada satisfactoriamente.

Todos los parámetros mostrados en la curva de cocción se pueden cambiar / editar de la misma manera.

Cambiar las opciones de programas

Presionando el botón [Opciones], se abrirá el menú para opciones de programas adicionales.

por ejemplo: Abrir el programa de protección de escritura

- A** En la pantalla del programa, pulse el botón [Parámetro].
- B** Presionar el botón [Opciones].
- C** Editar la opción deseada y volver al programa anterior presionando el botón de volver [Cerrar].



Presionando las flechas se pueden pasando las páginas de las opciones individuales.



Los programas de Ivoclar Vivadent están parcialmente bloqueados y no se pueden modificar. Consulte las instrucciones de uso si desea más información.

Programat[®] CS3

Guia Rápido

Prezado Usuário

Obrigado por ter adquirido o forno Programat CS3. Com o objetivo de tornar a configuração e o uso inicial do forno o mais fácil possível, preparamos este Guia Rápido.



As breves instruções deste Guia em hipótese alguma substituem as Instruções de Uso detalhadas. Por isso, pedimos por gentileza que você leia atentamente as Instruções de Uso e siga as observações lá contidas.

Desfrute seu trabalho com o Programat CS3.

1. Instalação

Remova os componentes do forno de sua embalagem e coloque a unidade em uma mesa apropriada. Por favor observe as instruções na embalagem externa. Certifique-se que a voltagem indicada na etiqueta de identificação é compatível com a rede elétrica. Em caso negativo, o forno não deve ser conectado.

A Montando a bandeja de resfriamento

Remova os dois parafusos da bandeja de resfriamento (1).

B Posicione a bandeja de resfriamento (2) na plataforma da estrutura (3).

Certifique-se que a bandeja de resfriamento está posicionada corretamente na plataforma da estrutura.

C Fixe a bandeja de resfriamento com os dois parafusos (1).

D Posicionando a plataforma de queima

A plataforma de queima (4) pode agora ser posicionada no suporte da plataforma de queima (5).

E Montando a cabeça do forno

A cabeça do forno é montada mais facilmente com o painel traseiro do forno voltado para o usuário. Erga a cabeça do forno com as duas mãos conforme a ilustração e coloque-a na base da cabeça do forno.

- F  Encaixe a cabeça do forno conforme a figura até sentir um clique na posição. Certifique-se que tanto a plataforma de queima como o isolamento não tenham sido danificados durante a montagem da cabeça do forno.

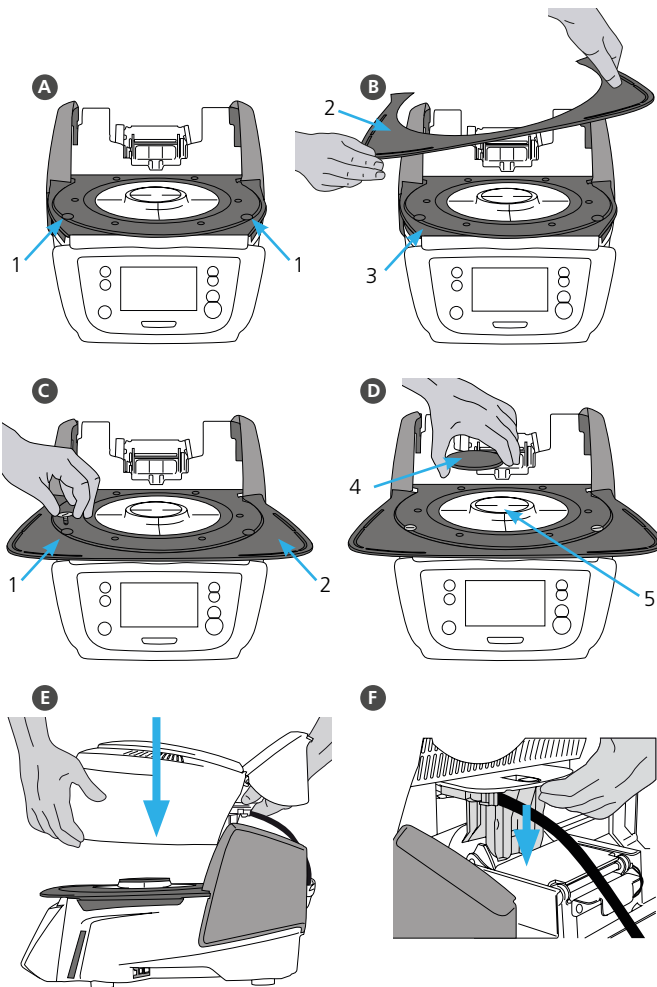

G Estabelecendo as conexões

Conecte os cabos da cabeça à base do forno. Prossiga deste modo:

- Conecte a mangueira do vácuo (6).
- Insira o plugue do termopar (7) (verifique se a polaridade do plugue está correta).
- Insira o plugue do aquecedor (8).

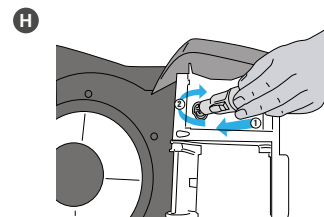
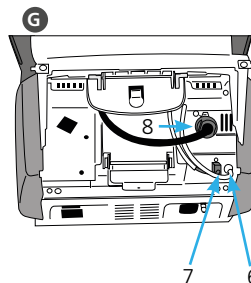

H Insira o plugue do aquecedor no conector indicado.

Trave o plugue do aquecedor girando-o 45°.

I Fechando a tampa de proteção

Quando todos os cabos estão conectados corretamente à base do forno, feche a tampa (9) para proteger as conexões até você sentir o clique indicando a posição.

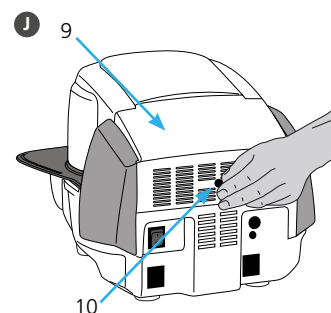
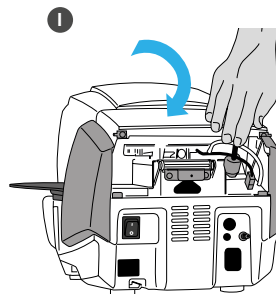

J Montando a tampa de conexão

A tampa de conexão (10) agora pode ser montada e presa com os parafusos.



O forno pode ser usado somente com a tampa de proteção fechada e a tampa de conexão montada!

K Estabelecendo as demais conexões

Conexão de energia

Certifique-se que a voltagem indicada na placa de classificação é compatível com a rede elétrica local. A seguir, conecte o cabo de força (11) à entrada de força do Programat (12).

Conectando a bomba de vácuo

Conecte o plugue da bomba de vácuo (13) à respectiva entrada (14). Recomendamos usar apenas a bomba à vácuo da Ivoclar Vivadent, pois estas bombas são especialmente coordenadas com o forno. Se outras bombas forem utilizadas, por favor atente para não ultrapassar o consumo máximo de energia indicado.

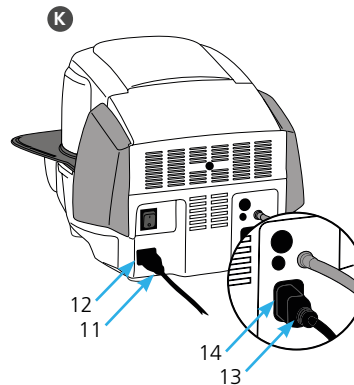

2. Interface do usuário

O forno Programat CS3 tem um visor em cores wide-screen. O painel e a tela de toque permitem fácil manipulação. Com um suave toque da ponta dos dedos na tela de toque, os botões são ativados e o forno executa a função solicitada.

Painel:



Início

Retorna à tela "Início" (menu principal)



Botão Economia de Energia

Este botão ativa a função de economia de energia.



Abra o cabeçote do forno



Feche o cabeçote do forno



START (LED Start)

Inicia o programa selecionado. O LED verde indica que um programa está em execução. Quando o programa é pausado (1 x STOP), o LED Start pisca até pressionar novamente START, o que continua o programa.



STOP

Um programa em execução pode ser pausado pressionando o botão STOP ou encerrado pressionando duas vezes. O movimento do cabeçote do forno pode ser parado a qualquer momento pressionando STOP. Os sinais sonoros podem ser desligados pressionando o botão STOP.



Botão Programa

Pressione uma vez: Exibe o programa selecionado atualmente.

Pressione duas vezes:

Acesso à seleção de programa digitando um número.



Tecla do Assistente Digital de Cor (Digital Shade Assistant – DSA)

Com esta chave, o Assistente Digital de Cor (DSA) pode ser iniciado e fechado.

3. Operação

A Ligando o forno

Conecte o cabo à tomada. Coloque o botão On/Off na posição "I".

Após o auto-teste, o visor mostra a tela inicial ou o último programa selecionado. Para mudar a tela inicial, pressione a tecla HOME. Todas as funções do Programat podem ser selecionadas a partir desta tela.

B Selecionando o programa

Selecione o programa requisitado.

Preenchendo o forno

Abra o cabeçote do forno pressionando o botão ABRA O CABEÇOTE DO FORNO e coloque o objeto a ser queimado na bandeja de queima no forno.

C Iniciando o programa

Pressione o botão START para iniciar o programa. O LED fica verde. É possível ver o progresso na curva de queima.

No final do programa, o cabeçote do forno se abre automaticamente. Assim que o OSD fica verde, o forno está apto para o próximo início de programa.

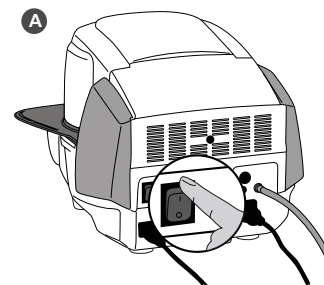

4. Editando os parâmetros de queima

Os parâmetros são determinados ou editados em dois passos.

Exemplo: Determinando a temperatura de espera

A Na tela de programa, pressione o botão [Parâmetro].

B Aperte o botão [T].

C Digite a temperatura de espera desejada e confirme pressionando o botão verde.

A temperatura de espera foi alterada com sucesso.

Todos os parâmetros mostrados na curva de queima podem ser alterados/editados do mesmo modo.

Alterando as opções de programa

Ao pressionar o botão [Opções], abre-se o menu para opções de programa adicionais.

por exemplo: Abrir a proteção de escrita do programa

A Na tela de programa, pressione o botão [Parâmetro].

B Pressione o botão [Opções].

C Edite a opção desejada e retorne à visualização do programa pressionando o botão [Fechar].

Pressionando os botões de [setas] você pode alternar as páginas de opção individuais.

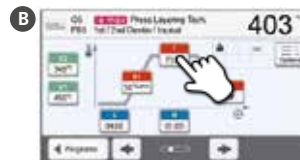

Os programas da Ivoclar Vivadent são parcialmente bloqueados e não podem ser editados. Por favor, siga as Instruções de Operação para informações mais detalhadas.

Ivoclar Vivadent – worldwide

Ivoclar Vivadent AG

Bendererstrasse 2
9494 Schaan
Liechtenstein
Tel. +423 235 35 35
Fax +423 235 33 60
www.ivoclarvivadent.com

Ivoclar Vivadent Pty. Ltd.

1 – 5 Overseas Drive
P.O. Box 367
Noble Park, Vic. 3174
Australia
Tel. +61 3 9795 9599
Fax +61 3 9795 9645
www.ivoclarvivadent.com.au

Ivoclar Vivadent GmbH

Tech Gate Vienna
Donau-City-Strasse 1
1220 Wien
Austria
Tel. +43 1 263 191 10
Fax: +43 1 263 191 111
www.ivoclarvivadent.at

Ivoclar Vivadent Ltda.

Alameda Caiapós, 723
Centro Empresarial Tamboré
CEP 06460-110 Barueri – SP
Brazil
Tel. +55 11 2424 7400
Fax +55 11 3466 0840
www.ivoclarvivadent.com.br

Ivoclar Vivadent Inc.

1-6600 Dixie Road
Mississauga, Ontario
L5T 2Y2
Canada
Tel. +1 905 670 8499
Fax +1 905 670 3102
www.ivoclarvivadent.us

Ivoclar Vivadent Shanghai Trading Co., Ltd.

2/F Building 1, 881 Wuding Road,
Jing An District
200040 Shanghai
China
Tel. +86 21 6032 1657
Fax +86 21 6176 0968
www.ivoclarvivadent.com

Ivoclar Vivadent Marketing Ltd.

Calle 134 No. 7-B-83, Of. 520
Bogotá
Colombia
Tel. +57 1 627 3399
Fax +57 1 633 1663
www.ivoclarvivadent.co

Ivoclar Vivadent SAS

B.P. 118
F-74410 Saint-Jorioz
France
Tel. +33 4 50 88 64 00
Fax +33 4 50 68 91 52
www.ivoclarvivadent.fr

Ivoclar Vivadent GmbH

Dr. Adolf-Schneider-Str. 2
D-73479 Ellwangen, Jagst
Germany
Tel. +49 7961 889 0
Fax +49 7961 6326
www.ivoclarvivadent.de

Ivoclar Vivadent Marketing (India) Pvt. Ltd.

503/504 Raheja Plaza
15 B Shah Industrial Estate
Veera Desai Road, Andheri (West)
Mumbai, 400 053
India
Tel. +91 22 2673 0302
Fax +91 22 2673 0301
www.ivoclarvivadent.in

Ivoclar Vivadent Marketing Ltd.

The Icon
Horizon Broadway BSD
Block M5 No. 1
Kecamatan Cisauk Kelurahan Sampora
15345 Tangerang Selatan – Banten
Indonesia
Tel. +62 21 3003 2932
Fax +62 21 3003 2934

Ivoclar Vivadent s.r.l.

Via Isonzo 67/69
40033 Casalecchio di Reno (BO)
Italy
Tel. +39 051 6113555
Fax +39 051 6113565
www.ivoclarvivadent.it

Ivoclar Vivadent K.K.

1-28-24-4F Hongo
Bunkyo-ku
Tokyo 113-0033
Japan
Tel. +81 3 6903 3535
Fax +81 3 5844 3657
www.ivoclarvivadent.jp

Ivoclar Vivadent Ltd.

12F W-Tower
54 Seocho-daero 77-gil, Seocho-gu
Seoul, 06611
Republic of Korea
Tel. +82 2 536 0714
Fax +82 2 596 0155
www.ivoclarvivadent.co.kr

Ivoclar Vivadent S.A. de C.V.

Calzada de Tlalpan 564,
Col Moderna, Del Benito Juárez
03810 México, D.F.
México
Tel. +52 (55) 50 62 10 00
Fax +52 (55) 50 62 10 29
www.ivoclarvivadent.com.mx

Ivoclar Vivadent BV

De Fruittuinen 32
2132 NZ Hoofddorp
Netherlands
Tel. +31 23 529 3791
Fax +31 23 555 4504
www.ivoclarvivadent.com

Ivoclar Vivadent Ltd.

12 Omega St, Rosedale
PO Box 303011 North Harbour
Auckland 0751
New Zealand
Tel. +64 9 914 9999
Fax +64 9 914 9990
www.ivoclarvivadent.co.nz

Ivoclar Vivadent Polska Sp. z o.o.

ul. Jana Pawla II 78
00-175 Warszawa
Poland
Tel. +48 22 635 5496
Fax +48 22 635 5469
www.ivoclarvivadent.pl

Ivoclar Vivadent LLC

Prospekt Andropova 18 korp. 6/
office 10-06
115432 Moscow
Russia
Tel. +7 499 418 0300
Fax +7 499 418 0310
www.ivoclarvivadent.ru

Ivoclar Vivadent Marketing Ltd.

Qlaya Main St.
Siricon Building No.14, 2nd Floor
Office No. 204
P.O. Box 300146
Riyadh 11372
Saudi Arabia
Tel. +966 11 293 8345
Fax +966 11 293 8344
www.ivoclarvivadent.com

Ivoclar Vivadent S.L.U.

Carretera de Fuencarral nº24
Portal 1 – Planta Baja
28108-Alcobendas (Madrid), Spain
Tel. +34 91 375 78 20
Fax +34 91 375 78 38
www.ivoclarvivadent.es

Ivoclar Vivadent AB

Dalvägen 14
S-169 56 Solna, Sweden
Tel. +46 8 514 939 30
Fax +46 8 514 939 40
www.ivoclarvivadent.se

Ivoclar Vivadent Liaison Office

: Tesvikkiye Mahallesi
Sakayik Sokak, Nisantas' Plaza No:38/2
Kat:5 Daire:24
34021 Sisli – Istanbul, Turkey
Tel. +90 212 343 0802
Fax +90 212 343 0842
www.ivoclarvivadent.com

Ivoclar Vivadent Limited

Compass Building
Feldspar Close
Warrens Business Park, Enderby
Leicester LE19 4SD, United Kingdom
Tel. +44 116 284 7880
Fax +44 116 284 7881
www.ivoclarvivadent.co.uk

Ivoclar Vivadent, Inc.

175 Pineview Drive
Amherst, N.Y. 14228, USA
Tel. +1 800 533 6825
Fax +1 716 691 2285
www.ivoclarvivadent.us



ivoclar
vivadent
passion vision innovation